

REFRIGERANT SYSTEM DIAGRAM

Models : **ABG14AGA-W / AOG14AGH**

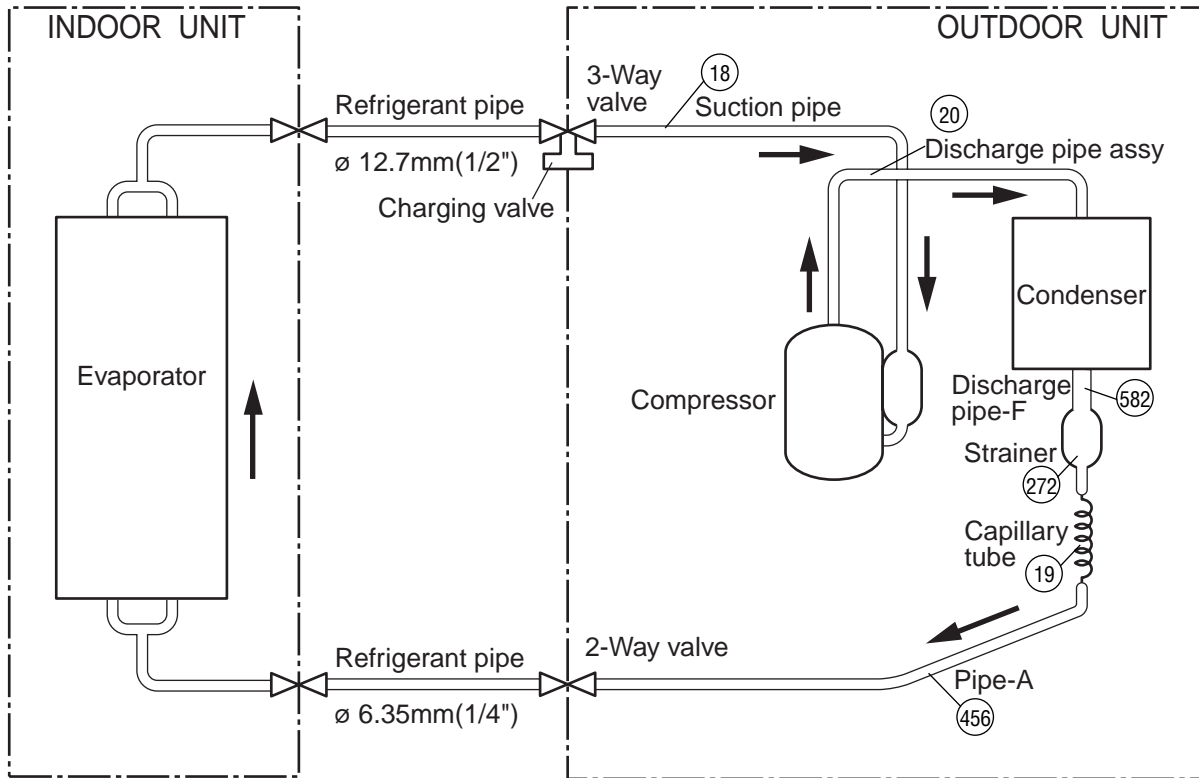

Models : **ABG14RGA-W / AOG14RGH**

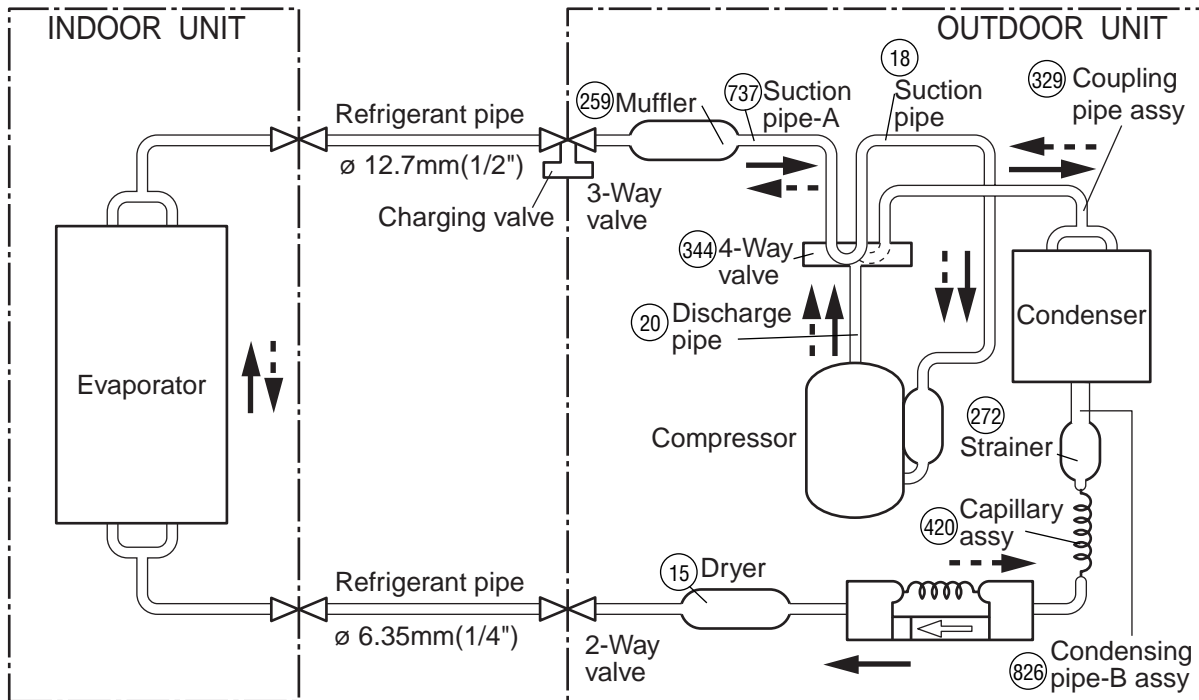

- Cooling
- - - - - Heating
- ⊗ : Flare coupling

Models : ABG18AGC-W / AOG18ANB

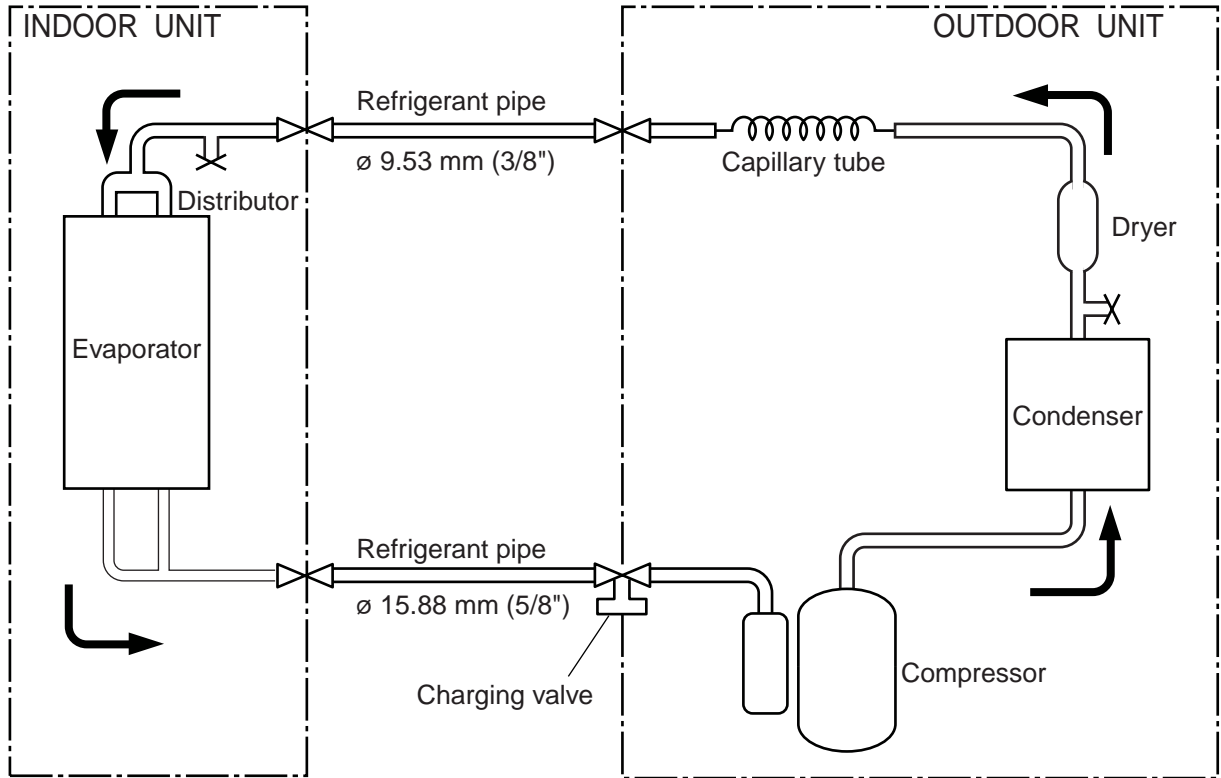

Models : ABG18RGB-W / AOG18RMAL

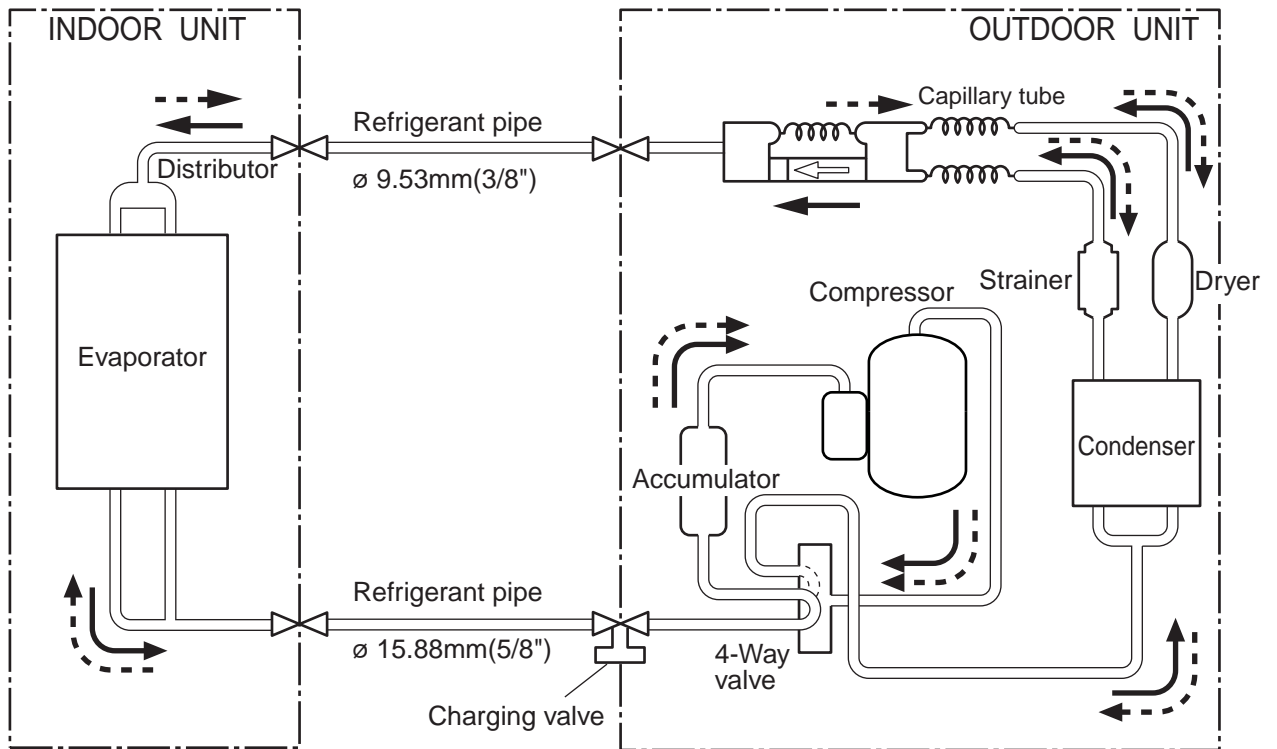

- Cooling
- - - - - Heating
- ⊗ : Flare coupling

Models : ABG24AGC-W / AOG24AMA

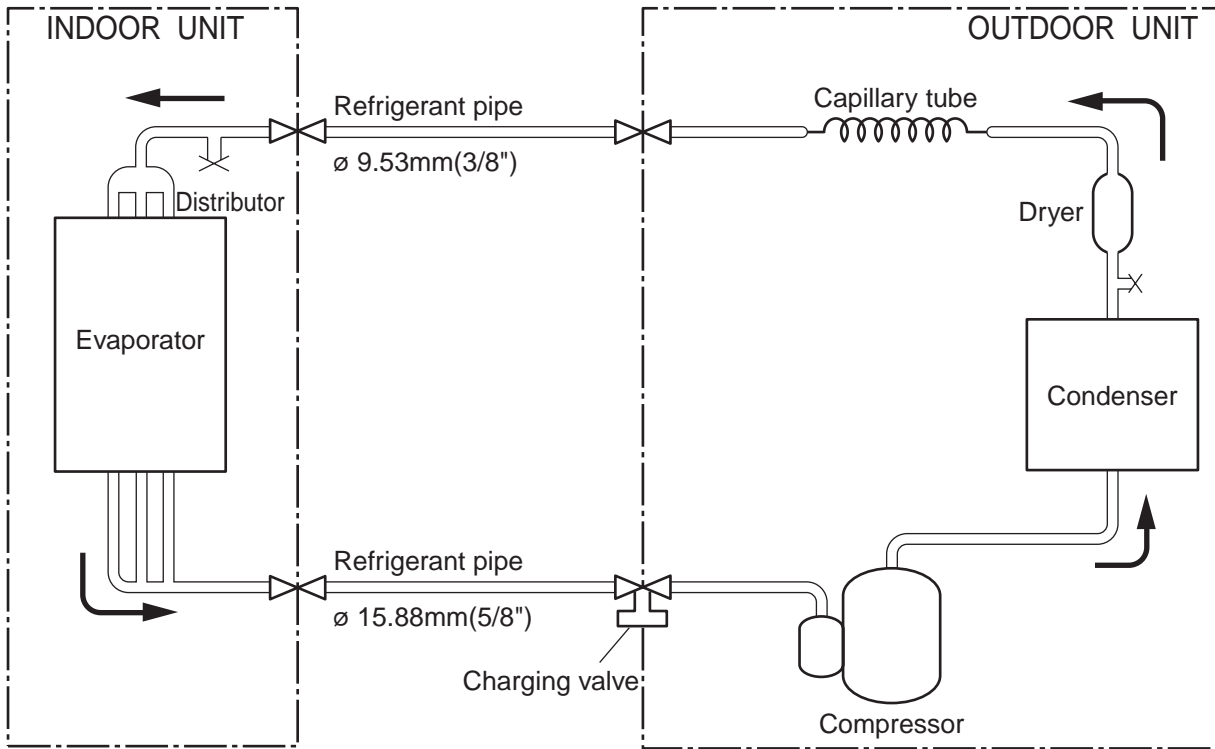

Models : ABG24RGB-W / AOG24RMBL

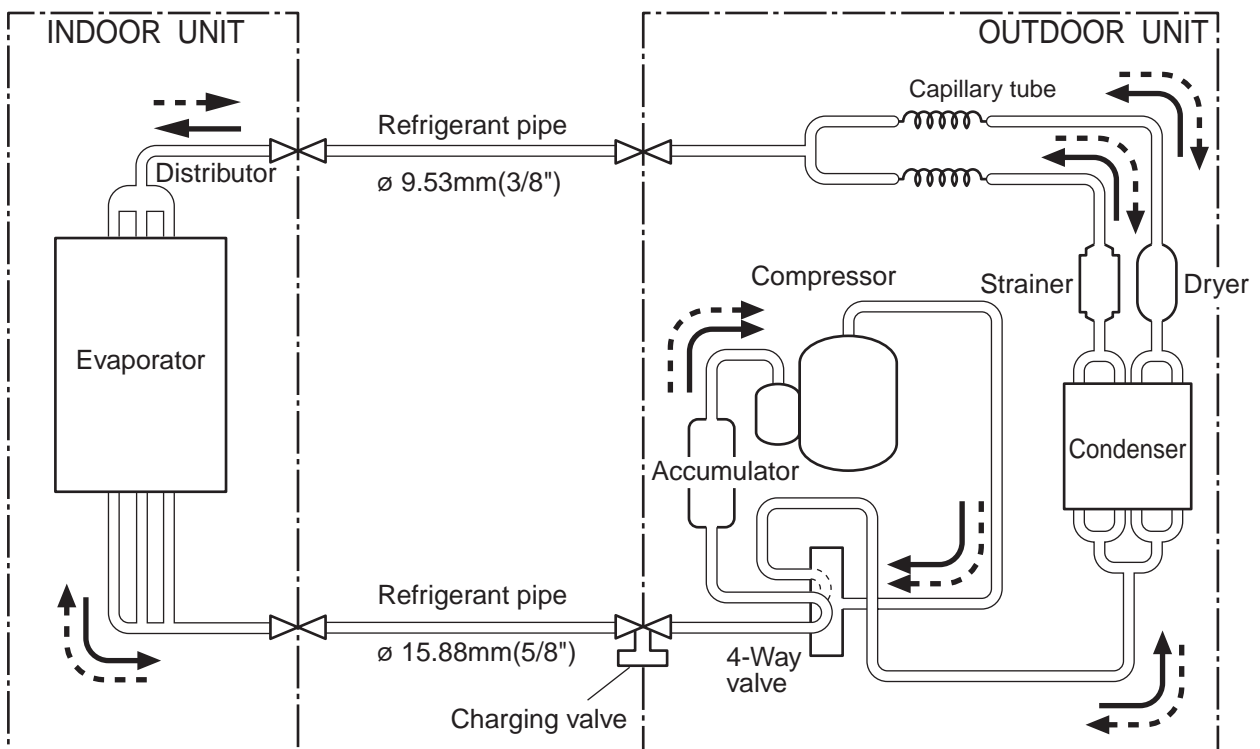

- Cooling
- - - -> Heating
- ⊗ : Flare coupling